

FERMAPORTE SOTTOTELAIO UNDER CHASSIS DOOR RETAINERS TÜRFESTSTELLER FÜR UNTERRAHMEN

In questo gruppo sono rappresentati diversi modelli di fermaporte.

- I fermaporte servono per trattenere la porta in apertura quando è affiancata alla parete del furgone, esistono due modelli fondamentali:
 - . Il primo composto da due parti, la parte maschio montata sulla porta e la parte femmina montata sulla parete.
 - Il secondo consta di un solo pezzo montato sotto il telaio.
-

This group contains several models of door stays.

- The door retainers are used for keeping the door open when it is against the body of the van. There are two basic models:
 - The first is composed of two parts, the male part mounted on the door and the female part mounted on the body.
 - The second consists of one piece mounted under the frame.
-

In dieser Gruppe sind verschiedene Modelle an Türfeststeller zu finden.

- Die Türfeststeller dienen dazu, die Tür bei deren Öffnung zurückzuhalten, wenn diese an die Seitenwand eines Transporters angelehnt werden soll, es gibt zwei Grundmodelle:
 - das erste Modell setzt sich aus zwei Teilen zusammen, aus dem an der Tür montierten Hakenteil teil und dem an der Wand montierten Halteteil.
 - das zweite Modell besteht aus einem einzigen Teil, das unter dem Rahmen montiert ist.

FERMAPORTE SOTTOTELAIO CARENATO
COVERED UNDER CHASSIS DOOR RETAINER
VERKLEIDETER UNTERRAHMEN-TÜRHALTER



0723 24937D

Fermaporte sottotelaio carenato
in alluminio anodizzato braccio in acciaio inox
impugnatura in gomma EPDM
Covered under chassis door retainer
in anodized aluminium, arm in stainless steel
handle in rubber EPDM
Verkleideter Unterrahmen -Türhalter
aus eloxiertem Aluminium, Haltearm aus Nirosta
Griff aus EPDM Gummi
g. 1850



0723 25051

Kit staffe inox per fissaggio fermaporte sottotelaio
carenato
Set of S.S. fixing brackets for covered under chassis
door retainer
Befestigungskit aus Nirosta für verkleideten Unterrahmen-
Türhalter
g. 157

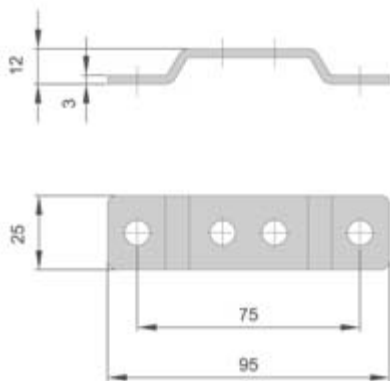
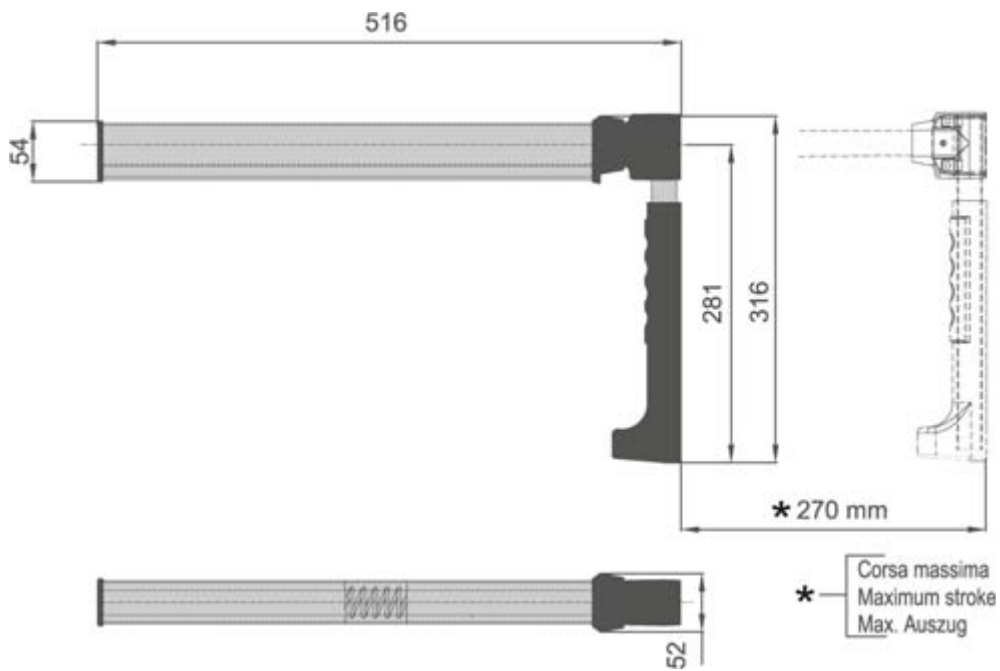

Kit specifico per il fermaporte sottotelaio carenato
art. 0723 24937D composto da 2 staffe, 4 viti , 4 rosette

Specific set for covered under chassis door retainer item
no. 0723 24937D composed of 2 brackets, 4 screws,
4 washers

Kit speziell für verkleideten Unterrahmen-Türhalter
Art. 0723 24937D, bestehend aus 2 Haltern, 4 Schrauben,
4 Unterlegscheiben

**FERMAPORTE SOTTOTELAIO
UNDER CHASSIS DOOR RETAINERS
TÜRFESTSTELLER FÜR UNTERRAHMEN**

INOX-S.S.-NIROSTA

ZINC. - Z.PL. - VERZ.

0723 25818

Fermaporte sottotelaio con squadretta e molla in acciaio protetta con Bezinal
Under chassis door retainer with square and bezinal protected spring
Türhalter für Unterrahmen mit Befestigungswinkel und Bezinal-beschichteter Feder
g. 2200



0723 25816

Fermaporte sottotelaio con molla in acciaio inox
Door retainer with s.s. spring
Türfeststeller für Unterrahmen mit Nirosta-Feder
g. 1800

0723 25817

Fermaporte sottotelaio con molla in acciaio protetta con Bezinal
Door retainer with Bezinal protected spring
Türfeststeller für Unterrahmen mit Bezinal-beschichteter Feder
g. 1800



0723 25821

Fermaporte sottotelaio con molla in acciaio inox
Door retainer with s.s. spring
Türfeststeller für Unterrahmen mit Nirosta-Feder
g. 1810



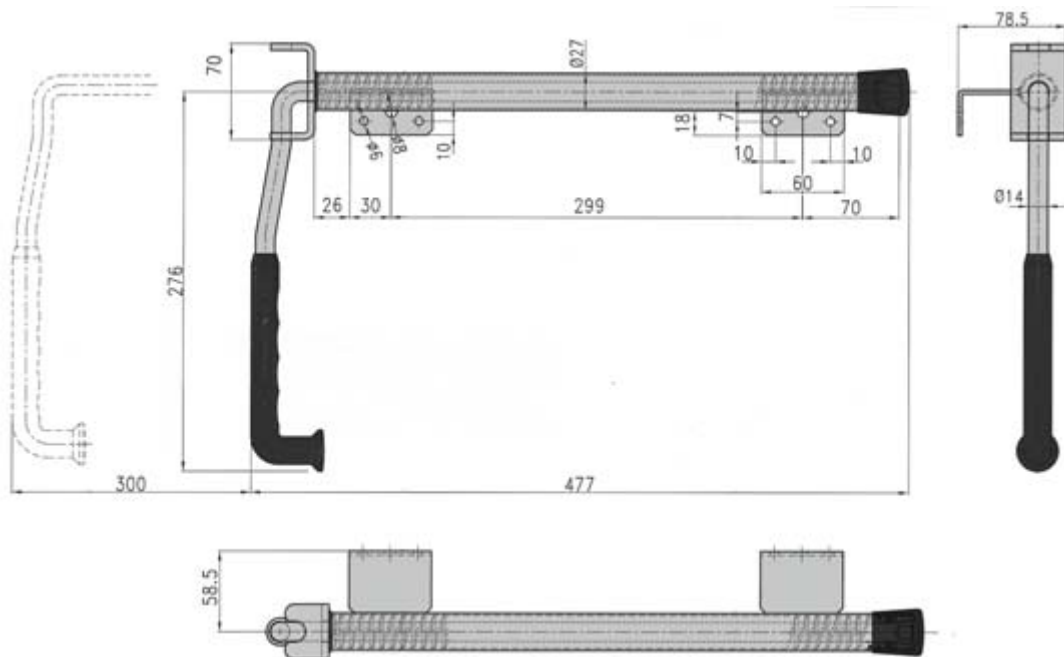
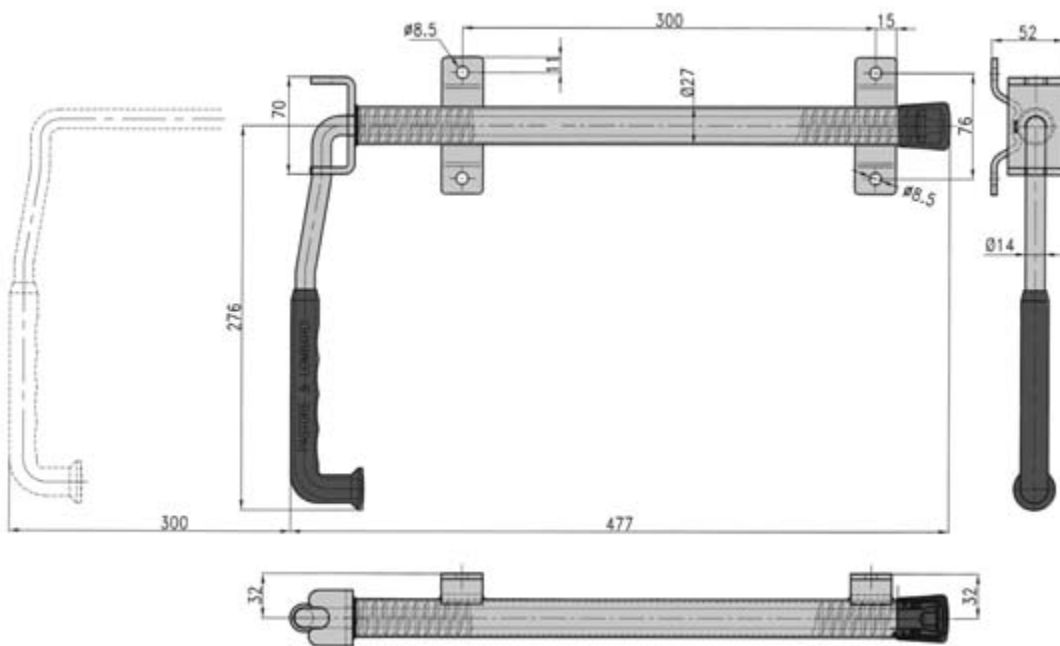
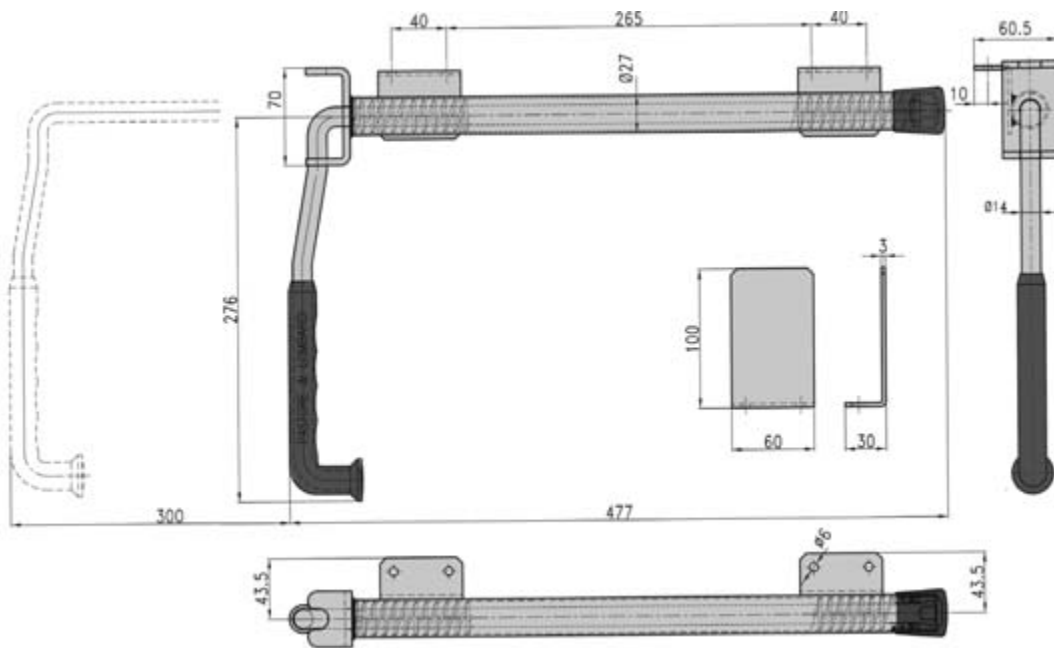

INOX - S.S.- NIROSTA



0723 20382 mm. 103 - g. 120

0723 20381 mm. 123 - g. 123

0723 23683 mm. 143 - g. 130

Fermaporte completo
Complete door retainer
Kompletter Türfeststeller
(Confezione pz. 6
Packaging of 6 pcs
Packung aus 6 Stk.)

RICAMBI - SPARE PARTS - ERSATZTEILE



0723 24765

Piastrina- Plate- Plättchen
g. 27

ACCESSORI - ACCESSORIES - ZUBEHÖR



0723 20865

Piastrina- Plate- Plättchen
g. 18

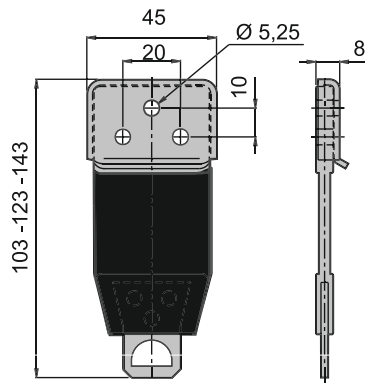

Fermaporte parte maschio in poliuretano e acciaio Inox
 Male part of door retainer in polyurethane and S. S.
 Türhalter, Hakenteil aus Polyrethan und Nirosta

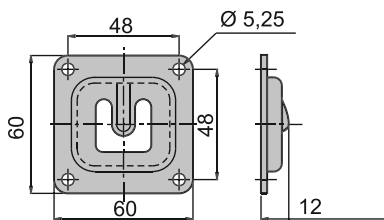

Fermaporte parte femmina in acciaio Inox
 Female part of door retainer in S. S.
 Türhalter, Halteteil aus Nirosta

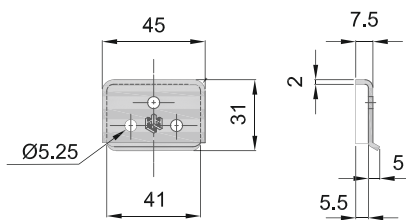

Piastrina in acciaio inox per fermaporte in poliuretano
 S.S. plate for door holder in polyurethane
 Plättchen aus Nirosta für Türhalter in Polyurethan

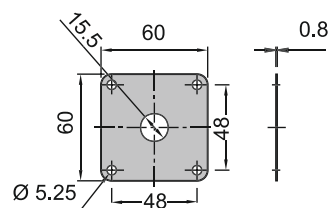

Piastrina per parte femmina fermaporte
 Il foro centrale della piastrina e' richiesto per
 le verifiche doganali.

Plate for female part of door holder
 The plaque's central hole is required for
 customs control.

Plättchen für Halteteil des Türhalters
 Die zentrale Bohrung im Plättchen ist bei
 Zollprüfungen erforderlich.

INOX - S.S.- NIROSTA

ZINC. - Z.PL. - VERZ.



0723 10944 mm. 104 g. 54
0723 10945 mm. 122 g. 56

Fermaporte parte maschio
Male part of door stay
Türhalter, Hakenteil
(Confezione pz.20
Packaging of 20 pcs
Packung aus 20 Stk.)

0723 10946 mm. 104 g. 54
0723 10947 mm. 122 g. 56

Fermaporte parte maschio
Male part of door stay
Türhalter, Hakenteil
(Confezione pz.20
Packaging of 20 pcs
Packung aus 20 Stk.)



0723 22748

Fermaporte parte femmina
Flush female part
Türfeststeller, Halteteil
g. 45
(Confezione pz. 20
Packaging of 20 pcs
Packung aus 20 Stk.)

0723 22749

Fermaporte parte femmina
Flush female part
Türfeststeller, Halteteil
g. 45
(Confezione pz. 20
Packaging of 20 pcs
Packung aus 20 Stk.)

ACCESSORI - SPARES - ZUBEHÖRE

0723 12525

Protezione in PVC nero
PVC protection plate
Schutz aus schwarzem PVC
g. 10
(pz. 20 - 20 pcs - 20 Stk.)



0723 12524

Protezione in PVC nero
PVC protection plate
Schutz aus schwarzem PVC
g. 8
(pz. 20 - 20 pcs - 20 Stk.)



0723 01449

Fermaporte automatico
Complete automatic door holder
Automatischer Türfeststeller
g. 195
(Confezione pz. 10
Packaging of 10 pcs
Packung aus 10 Stk.)



RICAMBIO - SPARE - ERSATZTEIL

0723 19804

solo parte maschio
male part only
nur Hakenteil
g. 114 (pz.10-pcs.10-10 Stk)



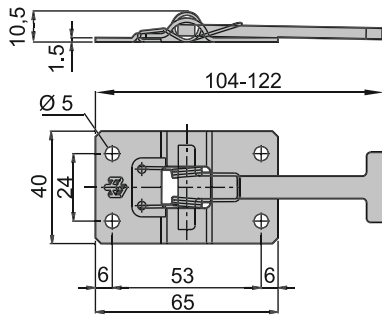

Fermaporte parte maschio con molla di ritorno
Male part of door stay with spring return
Türhalter, Hakenteil mit Rückholfeder

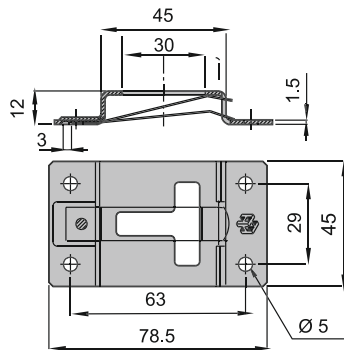

Fermaporte parte femmina esterna
External female part of door retainer
Türhalter, Halteteil

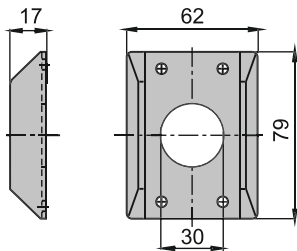

Il foro centrale e' richiesto per le verifiche doganali
The central hole is required for customs control
Die zentrale Bohrung ist bei Zollprüfungen erforderlich

ACCESSORI - SPARES - ZUBEHÖRE

Per - for - für: Art. 0723 22748 - 0723 22749

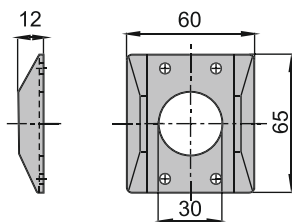

Per - for - für:
Art. 0723 10944 - 0723 10945 -
0723 10946 - 0723 10947

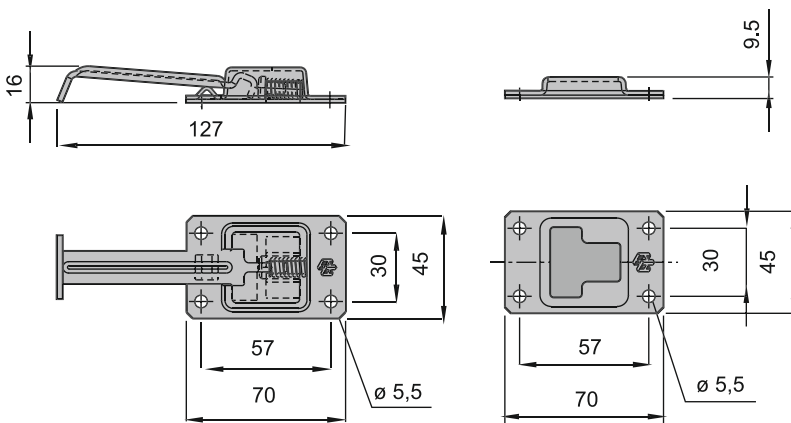

Fermaporte a chiusura automatica:
per l'uso occorre alzare la leva della parte maschio che si
inserirà automaticamente nella parte femmina al contatto delle
due parti.

Door retainer with automatic close:
to use, raise the lever of the male part which will automatically
be inserted into the female part upon the contact of the two
parts.

Automatisch schließender Türhalter:
für die Anwendung reicht es aus,
den Hebel des Hakenteils anzuheben,
der sich automatisch bei Kontakt
der beiden Teile in das Halteteil einfügt.

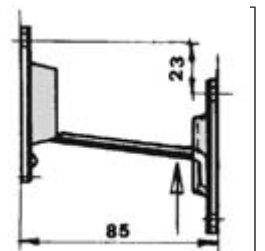



0723 01288 mm. 30 - g. 42
0723 01292 mm. 40 - g. 46
0723 01290 mm. 50 - g. 55
0723 01291 mm. 60 - g. 60
0723 01289 mm. 80 - g. 74
Perno - Pin - Zapfen



0723 01296

Portagomma
Housing
Gummihalter
g. 40



0723 01295A

Tassello in gomma
Rubber female piece
Gummidübel
g. 36



0723 01333

Perno - Pin - Zapfen
g.6



0723 01332

Portagomma in alluminio lucido
Aluminium housing
Gummihalter aus Glanzaluminium
g. 12



0723 01331A

Tassello gomma
Rubber female piece
Gummidübel
g. 4



0723 01080

Fermaporte completo
Complete door retainer
Kompl.Türfeststeller
g. 55 (pz. 50 - 50 pcs - 50 Stk.)



0723 12898

Fermaporte completo
Complete door retainer
Kompl.Türfeststeller
g. 40
(pz. 50 - 50 pcs - 50 Stk.)

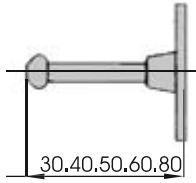

Perno in ottone nichelato
Nickel-plated brass pin
Vernickelter Messingzapfen

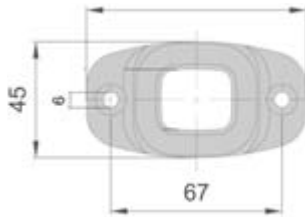

Portagomma in alluminio lucido per tutti i perni
Shiny aluminum seal holder for all pins
Gummihalter aus Aluminium für alle Zapfen



Tassello fermaporte in gomma per tutti i perni
Rubber door stay block for all pins
Gummidübel für alle Zapfen

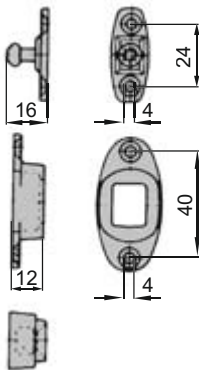

Perno in ottone nichelato
Nickel-plated brass pin
Vernickelter Messingzapfen

Portagomma in alluminio lucido
Shiny aluminum seal holder
Gummihalter aus glänzendem Aluminium

Tassello fermaporte in gomma
Rubber door stay block
Gummidübel

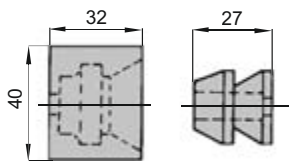

Fermaporte in gomma con perno in plastica
Rubber door retainer with plastic pin
Türfeststeller aus Gummi mit Kunststoffzapfen

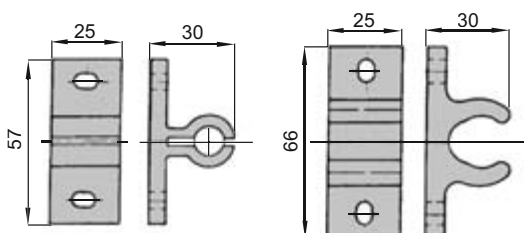

Fermaporte in nylon bianco
White nylon door retainer
Türfeststeller aus weißem Nylon