

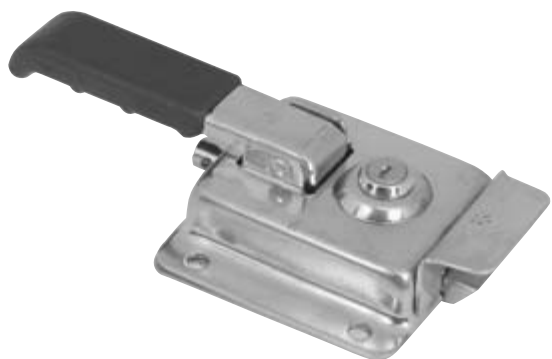

INOX - S.S.- NIROSTA



0716 25856

Serratura con chiave, senza scontro
Lock with key, without keeper
Verschluß mit Schlüssel, ohne
Gegenhalter
g. 1200
(Confezione pz. 2
Packaging of 2 pcs
Packung aus 2 Stk.)



0716 25857

Scontro da incasso per art. 0716 25856
Recessed catch for art. 0716 25856
Einlaßgegenhalter für art. 0716 25856
g. 250
(Confezione pz. 2
Packaging of 2 pcs
Packung aus 2 Stk.)



0716 25858

Scontro a filo per art. 0716 25856
Flush mounted catch for art. 0716 25856
Aufliegender Gegenhalter für art. 0716 25856
g. 275
(Confezione pz. 2
Packaging of 2 pcs
Packung aus 2 Stk.)

RICAMBI PER - SPARE PARTS FOR - ERSATZTEILE FÜR Art. 0716 25856



0719 22701A

Nottolino chiave 180° con toppa
Key barrel with cover device
Schließzylinder mit Schutzvorrichtung
g. 48



0719 15479

Linguetta - Tongue - Zunge
g. 10



0719 21934

Molla - Spring - Feder
g. 13

Serratura da incasso senza scontro per porte laterali, specialmente usata nei furgoni per consegne gelati e surgelati. Quando è chiusa a chiave la leva si può alzare ma non agisce sul nasello.

Recessed lock without keeper for side doors, specially used in vans for delivering ice cream and frozen food products. When locked, the lever can be raised but does not come into contact with the nib.

Einbauschloß ohne Gegenhalter für kleine Seitentüren, wird besonders bei Eis- und Tiefkühllieferwagen verwendet. Wenn mit Schlüssel abgesperrt, ist es möglich, den Hebel anzuheben, was aber dann keinerlei Auswirkung auf den Schließkeil hat.

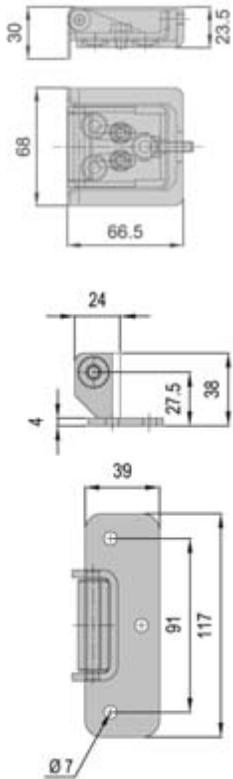
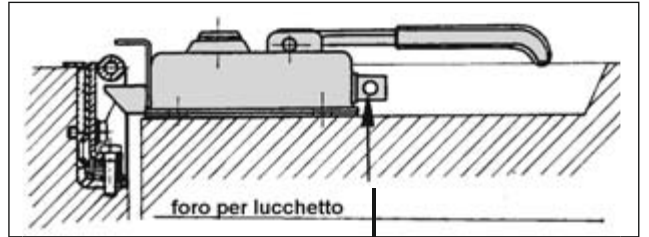
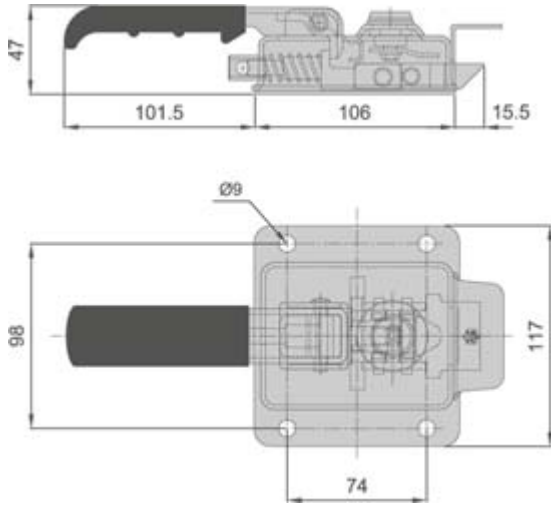

Scontro inox da incasso con rullino regolabile in altezza tramite viti e spessori.
S.S. recessed catch with roll adjustable in height by screws and shims
Einlaßgegenhalter aus Nirosta mit in der Höhe durch Schrauben und Unterlegplatten regulierbarer Rolle

Scontro inox a filo con rullino non regolabile in altezza
Flush mounted S.S. catch with roll not adjustable in height
Aufliegender Gegenhalter aus Nirosta mit nicht in der Höhe regulierbarer Rolle

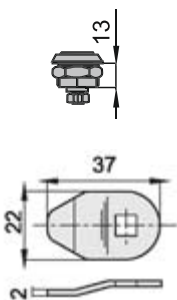

Per art.- for art.- für art. - 0716 25856

Per art.- for art.- für art. 0716 25856

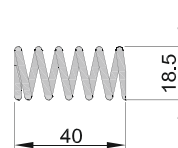

Molla nasello per art. 0716 25856

Spring for nib art. 0716 25856

Feder für Schliessekeil
art. 0716 25856

**SERRATURA DA INCASSO
RECESSED DOOR LOCK
EINLASS-TÜRSCHLOSS**

INOX - S.S.- NIROSTA

0716 26109

Serratura incassata con chiave
completa di scontro
Recessed lock with key and keeper
Einlasschloss mit Schlüssel und Gegenhalter
g. 1400
(Confezione pz. 8
Packaging of 8 pcs
Packung aus 8 Stk.)



RICAMBI SPARE PARTS - ERSATZTEILE

0719 26153

Nottolino chiave 90° con toppa
Key barrel 90° with cover device
Schließzylinder 90° mit Schutzvorrichtung
g. 48

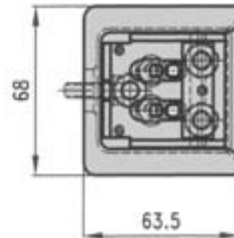
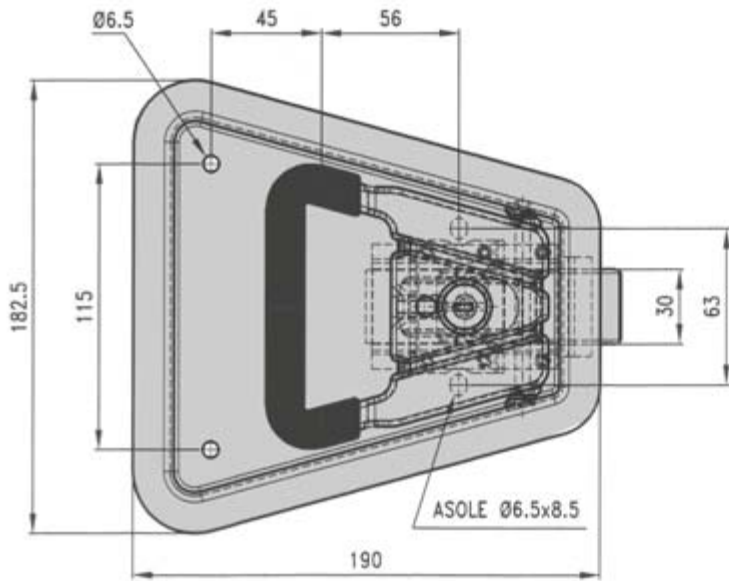
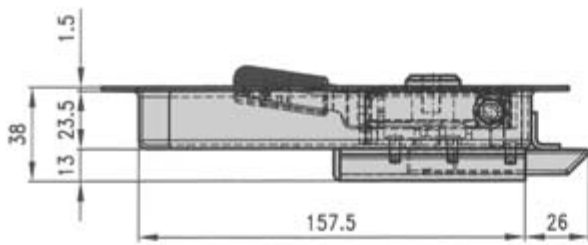

Serratura incassata completa di scontro per porte laterali. Quando è chiusa a chiave la maniglia non può essere alzata. Il rullino dello scontro è regolabile in altezza tramite viti e spessori.

Recessed lock complete with striker for side doors. When locked, the handle cannot be raised. The striker roll is height adjustable by means of screws and shims.

Einbauschoß komplett mit Gegenhalter für Seitentüren. Wenn mit Schlüssel abgesperrt, kann der Griff nicht angehoben werden. Die Höhe der Gegenhalterrolle ist über Schrauben und Zwischenlegscheiben einstellbar.

